

DEXIBELL

VIVO | H6 |

h o m e p i a n o

Quick Guide



HANDMADE
IN ITALY

Regulatory and Safety Information

Users in U.S.A

This product has been tested and found to comply with the limits for a Class B digital devices, pursuant to Part 15 of the FCC Rules. These limits are designed to provide reasonable protection against harmful interference in a residential installation. This equipment generates, uses, and can radiate radio frequency energy and, if not installed and used in accordance with the instructions, may cause harmful interference to radio communications. However, there is no guarantee that interference will not occur in a particular installation. If this equipment does cause harmful interference to radio or television reception, which can be determined by turning the equipment off and on, the user is encouraged to try to correct the interference by one or more of the following measures:

- Reorient or relocate the receiving antenna.
- Increase the separation between the equipment and receiver.
- Connect the equipment into an outlet on a circuit different from that to which the receiver is connected.
- Consult the dealer or an experienced radio/TV technician for help.

This device complies with part 15 of the FCC Rules. Operation is subject to the following two conditions:

- 1) This device may not cause harmful interference; and
- 2) This device must accept any interference received, including interference that may cause undesired operation.

FCC CAUTION: Any unauthorized changes or modifications not expressly approved by the party responsible for compliance could void the user's authority to operate the equipment.

NOTE: The manufacturer is not responsible for any radio or tv interference caused by unauthorized modifications to this equipment. Such modifications could void the user's authority to operate the equipment.

Radiation Exposure Statement

This product complies with the US portable RF exposure limit set forth for an uncontrolled environment and is safe for intended operation as described in this manual. Further RF exposure reduction can be achieved if the product is kept as far as possible from the user body or is set to a lower output power if such function is available.

This transmitter must not be co-located or operated in conjunction with any other antenna or transmitter.

Users in Canada

This device complies with Industry Canada's licence-exempt RSSs. Operation is subject to the following two conditions:

- (1) this device may not cause interference, and
- (2) this device must accept any interference, including interference that may cause undesired operation of the device.

Le présent appareil est conforme aux CNR d'Industrie Canada applicables aux appareils radio exempts de licence. L'exploitation est autorisée aux deux conditions suivantes: (1) l'appareil ne doit pas produire de brouillage, et (2) l'utilisateur de l'appareil doit accepter tout brouillage radioélectrique subi, même si le brouillage est susceptible d'en compromettre le fonctionnement.

Radiation Exposure Statement

The product complies with the Canada portable RF exposure limit set forth for an uncontrolled environment and are safe for intended operation as described in this manual. The minimum separation distance for portable use is limited to 15mm assuming use of antenna with 2 dBi of gain. The further RF exposure reduction can be achieved if the product can be kept as far as possible from the user body or set the device to lower output power if such function is available.

Le produit est conforme aux limites d'exposition pour les appareils portables RF pour les Etats-Unis et le Canada établies pour un environnement non contrôlé. La distance de séparation minimale pour l'utilisation portative est limitée à 15mm en supposant l'utilisation de l'antenne avec 2 dBi de gain. Le produit est sûr pour un fonctionnement tel que décrit dans ce manuel. La réduction aux expositions RF peut être augmentée si l'appareil peut être conservé aussi loin que possible du corps de l'utilisateur ou que le dispositif est réglé sur la puissance de sortie la plus faible si une telle fonction est disponible.

Users in EU

This device complies with the essential requirements of the 2014/53/EU – Radio Equipment Directive (RED). The following test methods have been applied in order to prove presumption of conformity with the essential requirements of the 2014/53/EU – Radio Equipment Directive (RED):

- EN 62368-1:2014/A11:2017
Safety requirements for audio/video, information, and technology equipment
- EN 300 328 v2.2.2 (2019-07)
Wideband transmission systems; Data transmission equipment operating in the 2,4 GHz band; Harmonized Standard for access to radio spectrum
- EN 62311:2008 | EN 50385:2017
RF exposure
- EN 301 489-1 v2.2.0 (2017-03)
Electromagnetic compatibility and Radio Spectrum Matters (ERM); ElectroMagnetic Compatibility (EMC) standard for radio equipment and services; Part 1: Common technical requirements
- EN 301 489-17 V3.2.0 (2017-03)
Electromagnetic compatibility and Radio spectrum Matters (ERM); ElectroMagnetic Compatibility (EMC) standard for radio equipment and services; Part 17: Specific conditions for 2,4 GHz wideband transmission systems and 5 GHz high performance RLAN equipment
- EN 301 893 v2.1.1 (2017-05)
5 GHz RLAN; Harmonized Standard covering the essential requirements of article 3.2 of Directive 2014/53/EU
- EU 2015/863 (RoHS 3)
Declaration of Compliance – EU Directive 2015/863; Reduction of Hazardous Substances (RoHS)

VIVO | H6

h o m e p i a n o

Quick Guide

Welcome to the quick guide of VIVO H6 Digital Piano, and congratulations on purchasing it.

The VIVO H6 Digital Piano uses Dexibell's latest technology to give players the ultimate piano sound.

*With its **88-note Progressive Hammer-Action keyboard with escapement** and high quality stereo-sampled piano sounds, VIVO H6 offers players the ultimate piano sound.*

*All sounds were recorded with the holophonic method for a unique 3D listening experience and reproduced using the new technology called **T2L (True to Life)**, based on an interaction between sampling and modelling methods. Moreover, the sound quality has been enhanced to **24-bit - 48KHz**, and the recorded samples are now five times longer on average (15" on lower piano notes).*

*VIVO H6 reproduces a real acoustic piano also thanks to **unlimited notes polyphony** (320 oscillators).*

The accurate sustain pedal simulation is designed for a good-feeling response and allows subtle performance nuances to be expressed.

To ensure maximum enjoyment and take full advantage of the piano functionality, please carefully read all sections of the complete owner's manual (Downloadable from the dexibell website).

Keep this manual handy for future reference.



Start to take advantage of valuable benefits available by simply registering your product on www.dexibell.com.

- You can benefit from DEXIBELL's **3-years** extended warranty (*The extended warranty is subject to terms and conditions. Please refer to the related section*).
- You can download the full version of the owner's manual.
- Keeps you updated on special offers.
- You can be updated on any new software release and new sounds.
- and so much more!

1 Important Safety Instruction

PLEASE READ CAREFULLY BEFORE PROCEEDING



WARNING

Only use non-tropical weather

This unit and its AC adaptor can only be safely used in non-tropical weather. The operating temperature range is 5° - 40°C (41° - 104°F).



Do not repair, modify or replace parts by yourself

Do not attempt to repair the unit, modify or replace parts of the product. Please contact all the nearest Dexibell Service Center.



Do not disassemble or modify by yourself

Do not open the unit or its AC adaptor or attempt to disassemble or modify the internal component in any way.



Use only the supplied AC adaptor (DEXIBELL DYS865-240250W).

Use only the AC adaptor included with the unit. Connecting a different AC adaptor can cause serious damage to the internal circuitry and may even pose a shock hazard.



Use only the supplied power cord

Use only the AC power cord supplied with the AC adaptor included in the package.



Do not excessively bend the power cord

Do not excessively twist or bend the power cord otherwise you damage it. Damaged cords may cause fire and shock hazards!



Do not place the unit in an unstable location

Do not place the unit in a unstable position where it might accidentally fall over.



Take care not to allow liquid or foreign objects to enter unit; Do not place containers with liquid on unit

Do not place object filled with liquid (glass of water on this product. Never allow foreign objects (e.g., flammable objects, coins, wires) or liquids (e.g., water or juice) to enter this product. Doing so may cause short circuits, faulty operation, or other malfunctions.



Never place or store the product in the following types of locations

- Exposed to extreme cold or heat (such as in direct sunlight, near a heater, or in a car during the day)
- Subject to steam or smoke
- Damp (such washroom, baths, on wet floors)
- Subject to salt water exposure
- Exposed to rain
- Dusty or sandy
- Subject to extreme changes of temperature or humidity (The condensation may occur and water may collect on the surface of the instrument. Wooden parts may absorb water and be damaged)
- Subject to high levels of vibration and shakiness.



Do not drop the unit or subject it to strong impact

Do not drop the unit. Protect it from strong impact!



Do not connect the unit to an outlet with an unreasonable number of other devices

Do not connect the unit's power-supply cord to an electrical outlet with an unreasonable number of other devices. This could cause the outlet to overheat and possibly cause a fire.



Adults must provide supervision in places where children are present

When using the unit in locations where children are present, never leave the unit unattended. Keep an eye on children so that they do not use the appliance improperly.



Avoid extended use at high volume

This unit, either alone or in combination with an amplifier and headphones or speakers, may be capable of producing sound levels that could cause permanent hearing loss. DO NOT operate for a long period of time at a high volume level, or at a level that is uncomfortable. If you experience any hearing loss or ringing in the ears, you should immediately stop using the unit, and consult an audiologist.



If you notice any abnormality turn off the unit immediately

Turn off the unit and remove the AC adaptor from the outlet when:

- If the AC adaptor, the power-supply cord, or the plug has been damaged
- If smoke or unusual smells occurs.
- If the product has been exposed to rain.
- If objects have fallen into, or liquid has been spilled into the unit.
- If the unit does not operate, or exhibits a marked change in performance.
- If the unit has been dropped, or the enclosure of the product has been damaged.



Contact the nearest qualified Service Center.



CAUTION

Grasp the plug connecting or disconnecting the AC adaptor

When removing the electric plug from the instrument or an outlet, always hold the plug itself and not the cord. Pulling by the cord can damage it.



Do not use wet hands to connect or disconnect AC adaptor

Never handle the AC adaptor or its plugs with wet hands when plugging into, or unplugging from, an electrical outlet.



Keep clean the AC adaptor's plug

At regular intervals, unplug the AC adaptor and using a dry cloth clean the adaptor's plug.



If the unit will be unused for an extended period of time, unplug the AC power cord from the AC outlet.

Keep cables from getting entangled

To avoid electric shock or damage to the unit, place all cords and cables away from children.



Before cleaning the unit, unplug the AC adaptor from the outlet

To avoid electric shock or damage to the unit, before cleaning the unit, turn it off and unplug the AC adaptor from the outlet (p. 10).



If there is a possibility of lightning strike in your area, disconnect the AC adaptor from the outlet

If you know a thunderstorm is predicted in your area, disconnect the AC adaptor from the outlet.



Take care so as not to get fingers pinched by lid

Be careful to avoid catching fingers (yours, or others, especially children's) when opening or closing the lid. Adult supervision is recommended whenever small children use the unit.



Do not rest your weight on or place heavy objects on the unit.

Avoid to climb on top of, nor place heavy objects on the unit.



Cautions when moving this unit

- When transporting or moving the unit always use two or more people. Attempting to lift the unit by yourself may damage your back, result in other injury, or cause damage to the unit itself.
- The unit should be handled carefully, all the while keeping it level.
- Disconnect the power cord and all connected cables.
- Close the lid.



Place in a well ventilated location

The unit and the AC adaptor should be located so their location or position does not interfere with their proper ventilation.



Do not use in tropical climates

Use the unit and the AC adaptor only in a moderate climates (not in tropical climates).



Place near the socket outlet

This equipment should be installed near the socket outlet and disconnection of the device should be easily accessible



Conventions Used in This Manual

The following symbols are used.

NOTE

It indicates an important note; be sure to read it.

MEMO

It indicates a memo regarding the setting or function; It's up to you read it.

TIPS

It indicates a useful hint for operation; read it as necessary.



This Symbol indicates that in EU countries, this product must be collected separately from household waste, as defined in each region. Products bearing this Symbol must not be discarded together with household waste.

For European Countries

2 Relevant Indications

In addition to the items listed under "Important Safety Instruction" on p. 4, please read and observe the following:



Power supply related

- Do not connect it to an AC outlet of voltage other than that for which your unit is intended.
- Do not plug this unit into the same electrical outlet used same by an electrical appliance that is controlled by an inverter or a motor (such as a refrigerator, washing machine or air conditioner). Doing so, can result an audible noise.
- The power adaptor may become warm after long hours of consecutive use. It can be a normal dissipation of heat through the adaptor casing. To reduce the possibility of overheating place the power adaptor on the floor in a well-ventilated location.
- Before connecting the unit to other equipment, turn off the power to all equipment. Otherwise, electrical shock or damage to the equipment may occur.
- If the unit is not operative for 120 minutes, to prevent unnecessary power consumption, this unit features an "AUTO OFF" function that automatically turns the unit off. If you don't want the unit to turn off automatically, change the "AUTO OFF" setting to "OFF" as described in the owner's manual.

NOTE

The "AUTO OFF" setting is memorized when you switch off the unit.



Related to appropriate location

- Do not place the unit near power amplifiers (or other equipment containing large power transformers) to avoid induced hum. In case of hum, to reduce the problem, change the orientation of your unit or place it away from the source of interference.
- Do not use this unit in the vicinity of a TV or radio. This unit may interfere with radio and television reception.
- When using this unit along with application on your iPhone/iPad, we recommend that you set "Airplane Mode" to "ON" on your iPhone/iPad in order to avoid noise caused by communication.
- Noise may be produced if cell phones are operated in the vicinity of this unit. In case of noise you should relocate such wireless devices so they are at a greater distance from this unit, or switch them off.
- Do not expose the unit to extreme cold or heat, to direct sunlight or near devices that radiate heat. Do not leave the unit inside a vehicle during the day. Extreme temperature can damage the unit.
- Take care when move the unit from one location to another with drastic changes in ambient temperatures. Condensation can occur in the unit due to drastic change of temperature. Using the device while condensation is present can cause damage. If there is reason to believe that condensation might have occurred, leave the device for several hours until the condensation has completely dried out.
- Do not place, for long periods of time, vinyl, plastic or rubber objects on this unit. Such objects can discolor or otherwise harmfully affect the finish.
- Do not place objects for long period of time on top of the keyboard. This can be the cause of malfunction of the keys of the keyboard.
- Do not apply any stickers, decals or self-adhesive material to this unit. The glue is difficult to remove and solvents are damaging the exterior finish.
- Do not place object filled with liquid (glass of water on this unit. Avoid to use alcohol, perfume, hairspray, nail polish, etc., near the unit. In the event of liquid spill on the unit, swiftly wipe away the surface using a dry, soft cloth.



Related to external memories

- Insert the USB Memory (commercially available) into the slot with care and at the correct angle.
- Take particular care when handling USB Memory:
 - Always ground yourself to something metal before handling a USB Memory
 - Do not touch the pins of the USB Memory connector, or allow them to become dirty.
 - Do not subject the USB Memory to temperature extremes (e.g., direct sunlight in an enclosed vehicle)
 - Do not allow the USB Memory to become wet
 - Do not drop or subject it to excessive shock or vibration.
- Do not disconnect the USB Memory while writing and reading data (i.e., while the USB Memory indicator blinks).
- Never use USB hub to connect USB Memory to the unit.
- This unit allows you to use commercially available USB Memory. You can purchase such devices at a computer store, a digital camera dealer, etc
- The audio recording require a USB storage device to support high sustained transfer rates. Not all USB devices will guarantee flawless performance.



Related to repairs

- Always back up your data on a USB memories before you send this unit for repair to an authorized center. All data contained in the unit's memory may be lost. Important data should always be backed up, or written down on paper (when possible). Dexibell assumes no liability concerning such loss of data.



Other precautions

- The contents of memory could be lost due to malfunction or improper operation. To help prevent the loss of your data, we highly recommend that you periodically save a backup copy of important data you have stored in the unit's memory on another storage device. (e.g., USB memories).
- Unfortunately, an error may occur during the data restore previously stored in the USB memories. Dexibell shall not be liable for loss of profits or any consequential loss, loss of data.
- Do not use excessive force when handling unit's buttons, switches, sliders and controls and when use connectors and jacks. Rough handling can cause damage o malfunctions.
- Do not to apply strong pressure on the display.
- Always pull by the connector when disconnecting a cable, never pull the cable Not doing so you will cause shorts, or damage to the cable's internal elements.
- Keep the unit's volume levels down. The instrument should be used at a reasonable volume, to avoid disturbing neighbours, especially at night and in the early morning. Use headphones if you want to play your music loud or late at night.
- When you need to transport the unit, put it in its original packaging with padding in the box. Otherwise, you will need to use equivalent packaging materials. When transporting or moving the unit always use two or more people.
- To prevent possible damage, avoid applying excessive force to the music stand.
- For connecting this unit use cable low impedance cables. The use of cables that contain resistor can cause the sound level to be extremely low, or impossible to hear.



Maintenance related

- To clean the unit, put a soft cloth in lukewarm water, squeeze it well, then wipe the entire surface using an equal amount of strength. Rubbing too hard in the same area can damage the finish.
- If your unit has a **polished finish**, it needs careful, periodic care. Dust should be removed using a soft feather or wool-type duster. Care should be taken not to apply pressure to the finish or to drag the dust across the finish, which can create fine scratches in the surface. Fingerprints or similar marks can be cleaned with a dampened soft cloth, followed by a dry cloth. In cases of stubborn greasy dirt, using a small amount of mild detergent (such as mild dishwashing liquid) on the damp cloth may help. Do not use any cleaners or detergents, since they might deteriorate the surface of the cabinet, and produce cracks. Do not use dusting cloths that contain chemicals.
- Do not wipe this unit with benzene, alcohol or solvent of any kind. Doing so may result in discoloration and/or deformation of the unit.



Related to copyright and trademarks

- Dexibell do not assume legal liability regarding any infringements of the user through the use of this unit.
- Recording, copying, distribution of copyrighted material (songs, live performance, etc.) belonging to a third party in part or in whole without the permission of the copyright owner is forbidden by law.
- Copyright © 2003 by Bitstream, Inc. All rights reserved. Bitstream Vera is a trademark of Bitstream, Inc.
- iPad® and iPhone® are registered trademarks of Apple Inc.
- App Store™ is an Apple's Service Mark
- The **Bluetooth®** word mark and logos are registered trademarks owned by Bluetooth SIG, Inc. and any use of such marks by Dexibell is under license.

3 Panel Description

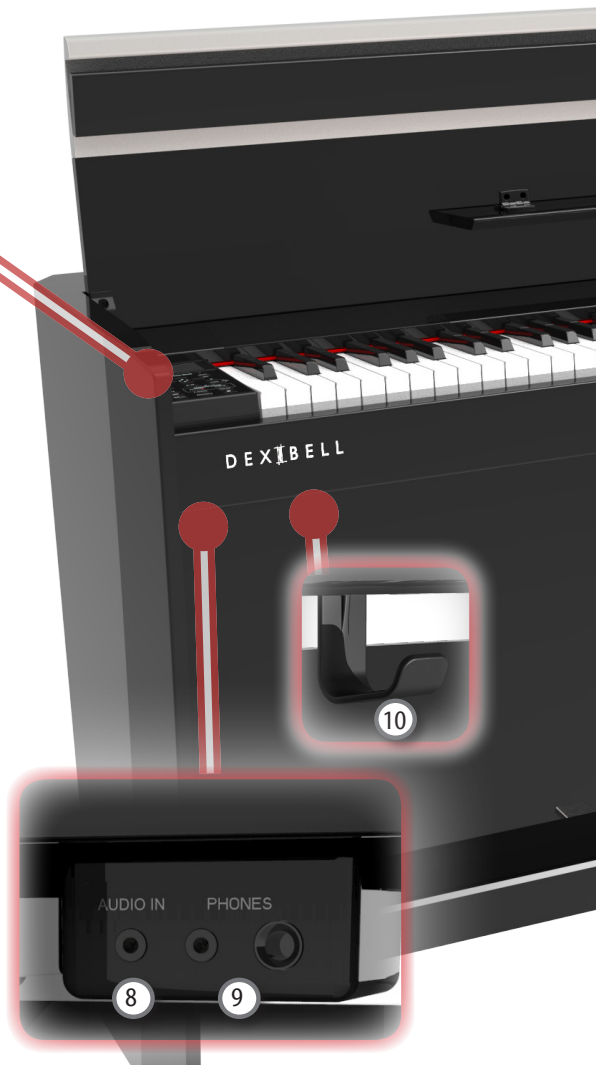
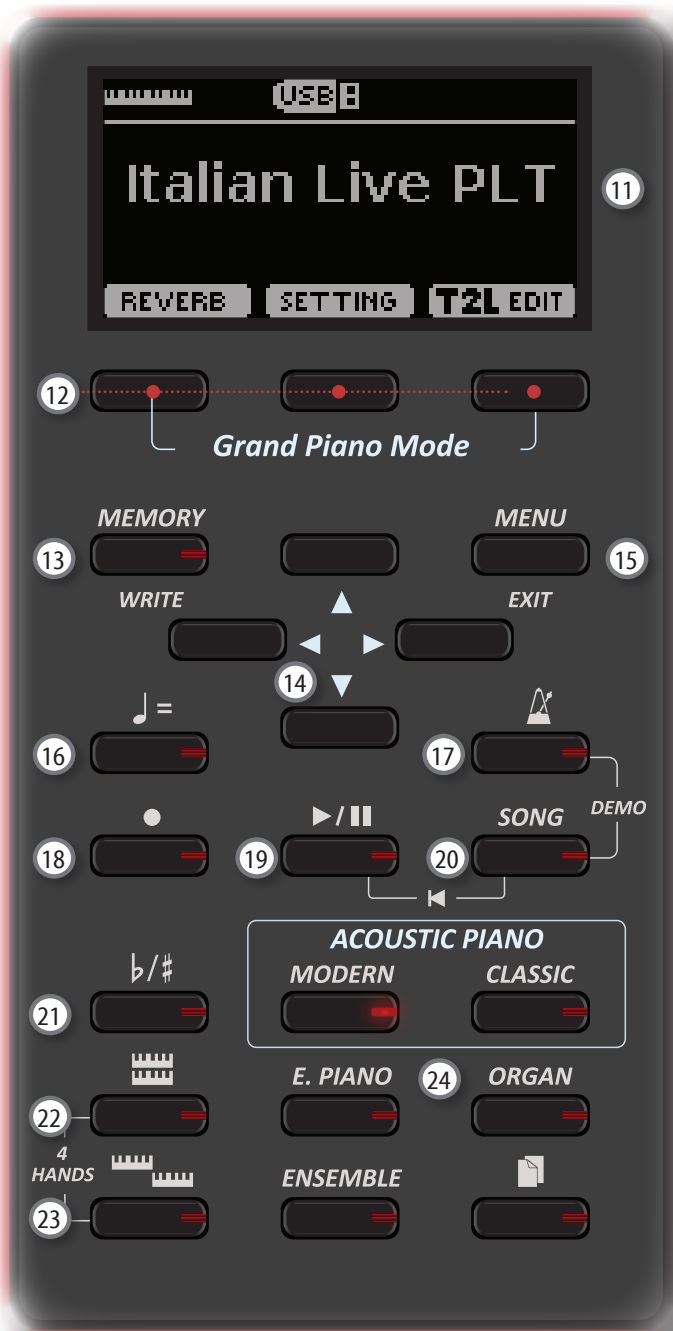

Turns the power on or off (p. 10).

With the factory settings, VIVO H6's power will automatically be switched off 120 minutes after you stop playing or operating the VIVO H6.

If VIVO H6's power has been turned off automatically, you can use the [POWER] switch to turn the VIVO H6 back on. If you don't want the power to turn off automatically, set the "AUTO OFF" parameter to "OFF".

NOTE

To avoid malfunctions, never disconnect the AC/DC adaptor while the instrument is turned on.

2 VOLUME

Use this knob to set VIVO H6's overall volume.

3 USB Computer Port

Use a USB cable to connect the VIVO H6 to your computer via this connector.

4 USB Memory Port

Connect a commercially available USB Memory here.

If you connect to this port a USB MIDI keyboard or modules, you can exchange MIDI data without a computer and without using two MIDI cables.

NOTE

* Carefully insert the USB Memory, ensuring that the connector on the device is appropriate and connected in the proper direction.

* Dexibell does not recommend using USB hubs, irrespective of whether they are active or passive. Please connect only one USB Memory to this port..

5 Damper Pedal

Use this pedal to sustain the sound.

6 Sostenuto Pedal

The notes you are pressing when this pedal is depressed will be sustained, allowing future notes played to be unaffected.

7 Soft Pedal

This pedal is used to reduce the volume and slightly change the timbre.

8 AUDIO IN

This mini jack allows you to connect the audio outputs of an external signal source (CD/mp3 player, etc.).

9 PHONES output

This is where you can connect one or two pairs of optional headphones. Doing so switches off the internal speakers.

10 Headphones Hook

Here you can hang your headphones.



11 Display

This display shows information related to your operation.

12 Function buttons

These buttons are used to select one of three functions/options shown at the bottom of the display.

13 MEMORY/WRITE button

This button allows you to show the list of memories and then recall one of them.

Pressing and holding this button to write a memory.

14 Arrow buttons

These buttons are used to navigate around the various menus, and adjust values.

15 MENU/EXIT

This button allows you to open and close the menu page where you can view and select all available functions.

16  (Tempo)

Use this button to change the tempo of the metronome. You can also enter tempos simply by tapping your finger on the button.

17  (Metronome)

This button allows you to turn the metronome on or off.

18  (Rec)

This button is used to start or stop the recording of your song.

19 

Press this button to start playing. Press it again to stop playing.

Press and hold it while pressing the [SONG] button to return to the beginning of the song.

20 SONG

This button allows you to switch to Song Mode.

Press it together with the  button to listen to the demo song.

21 

This button calls up the transposition function. Its settings can be applied to the keyboard.

If the button indicator doesn't light the instrument uses its normal pitch.

22 

This button enables or disables the layer keyboard mode.

Press it together with the  button to enable or disable the "4 HANDS" keyboard mode.

23 

This button enables or disables the split function.

Press it together with the  button to enable or disable the "4 HANDS" keyboard mode.

24 

These buttons allow you to select tones by category

Rear Side

VIVO H6

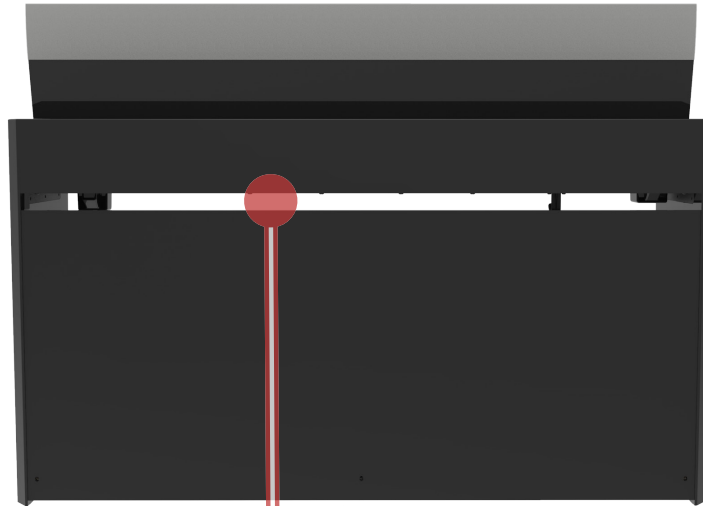

Rear View

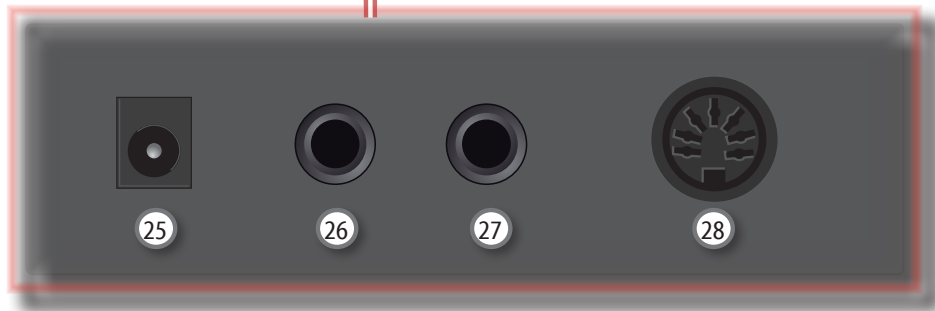

25 DC IN socket

Connect the supplied AC/DC adaptor here (p. 9).

26 AUDIO OUTPUT R jack

This socket allows you to connect an external amplified speaker.

27 AUDIO OUTPUT L/MONO jack

This socket allows you to connect an external amplified speaker.

NOTE

If you can/want to use only one channel on your external amplifier, connect this "L/MONO" socket to its input. For optimum sound quality, we recommend working in stereo, though.

28 Pedals Socket

Here is were you connect the pedal cable.

4 Before You Start to Play

Connecting the AC Adaptor

1. Rotate the [VOLUME] knob counterclockwise to minimize the volume.



2. Connect the included power cord to the AC adaptor.
To an AC outlet



NOTE

Depending on your area, the included power cord may differ from the one shown above.

NOTE

Be sure to use only the AC adaptor (DEXIBELL DYS865-240250W) supplied with the unit. Also, make sure the line voltage at the installation matches the input voltage specified on the AC adaptor body. Other AC adaptors may use a different polarity or be designed for a different voltage, so their use could cause damage, malfunction, or electric shock.

NOTE

If you won't be using the VIVO H6 for an extended period, disconnect the power cord from the electrical outlet.

NOTE

To avoid malfunctions, never disconnect the AC/DC adaptor while the instrument is turned on.

3. Connect the AC adaptor to VIVO H6's DC IN socket positioned in the rear bottom panel.

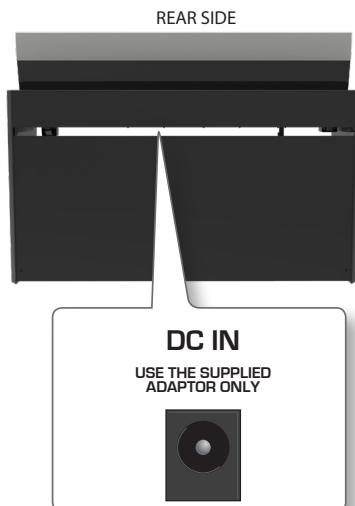

Connecting the Pedal Cord

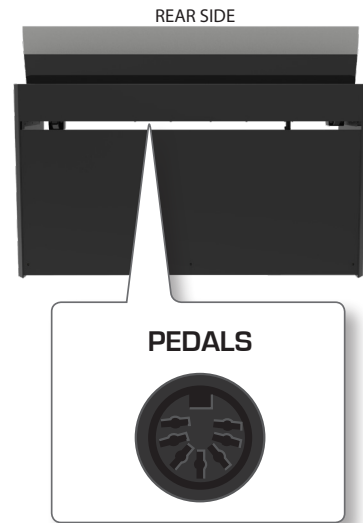

1. Connect the pedal cord that comes from the dedicated stand here.

For further information, see the Assembling Manual.

Opening and Closing the Lid

NOTE

- This unit has a safe closing system to avoid finger injuries when opening or closing the lid. Anyway, be careful to avoid catching your fingers when opening or closing the lid. Adult supervision is recommended whenever small children use the unit.
- If you need to move the unit, make sure that the lid is closed to prevent accidents.

Opening the Lid

WARNING

- Do not release the lid until it is fully opened.

1. Hold the front edge of the lid with both hands, then open the lid slowly until it reaches the end-of-stroke position.

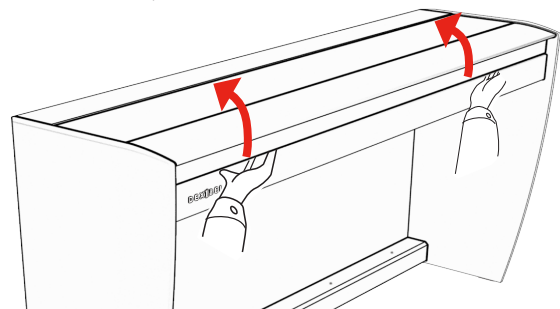

Using the Music Rest

Please find here below instructions regarding the opening and closing of the music rest.

Opening the Music Rest

1. Open the lid. See "Opening the Lid" just above.
2. Pull down the sheet music holder (1) as in the illustration below.
3. To provide extra space for the music sheet, pull down the front part of the lid (2), as in the illustration below.

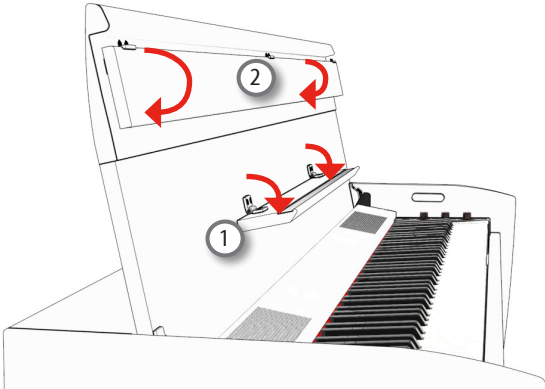

Closing the Music Rest

1. Pull up the sheet music holder (1) as in the illustration below.
2. Pull up the front part of the lid (2) as in the illustration below.

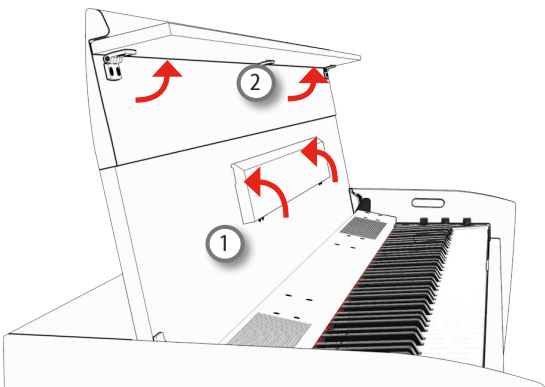

Closing the Lid

WARNING

- Allow the lid to close automatically. Do not force the lid.
- Be careful to avoid catching your fingers when closing the lid. Adult supervision is recommended whenever small children use the unit.

1. Before closing the lid, close the sheet music holder. See "Closing the Music Rest" as described above.
2. Hold the lid with both hands and slowly accompany it to close automatically.

Allow the lid to close automatically. Do not force the lid.

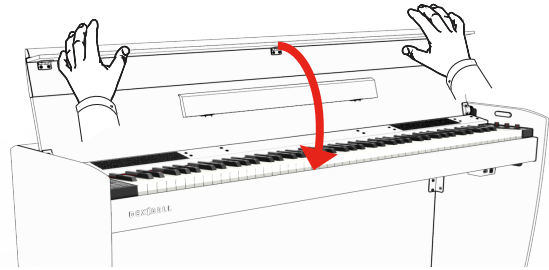

Turning the Power On/Off

Once everything is connected correctly, follow the procedure below to turn on the instrument.

1. Rotate the [VOLUME] knob counterclockwise to minimize the volume.

NOTE

Always turn the volume down before turning the VIVO H6 on/off. You might hear some sound when switching the VIVO H6 on/off, even with the volume turned down.

However, this is normal and does not indicate a malfunction.

2. Press the VIVO H6's [] button on the right panel to switch it on.



The power will turn on, and a progress bar appear in the VIVO H6's display.



After a brief interval, the main page will appear and VIVO H6 will be ready to produce sound.



3. Use the [VOLUME] knob to adjust the volume.

NOTE

This unit is equipped with a protection circuit. A brief interval (a few seconds) after power-up is required before the unit will operate normally.

Turning the Power Off

1. Rotate the [VOLUME] knob counterclockwise to minimize the volume.

NOTE

Never disconnect the AC/DC adaptor while the instrument is turned on to avoid malfunctions.

2. Press the VIVO H6's [⏻] switch.

A power-off confirmation message appears:

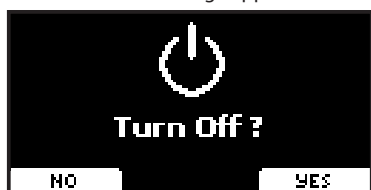

3. Press the "YES" Function button to confirm.

The display shows the following message:

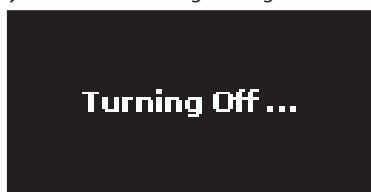

The unit will turn off after few seconds.

If you do not want power off, press the "NO" Function button.

NOTE

To completely power down the instrument, press the [⏻] button and unplug the power cord from the outlet. Refer to "Connecting the AC Adaptor" (p. 9).

If you do not operate the unit for a certain of time while the power is on, this unit turns off automatically.

If you don't want the power to turn off automatically, turn off the "AUTO OFF" setting!

With the factory settings, the unit's power will automatically be switched off 120 minutes after you stop playing or operating the unit.

Shortly before the VIVO H6 shuts down automatically, the display counts down the seconds. Press any button if you want to keep using the VIVO H6 at this stage.

If you don't want the power to turn off automatically, change the "AUTO OFF" setting to "OFF".

Demo of the VIVO H6

Your VIVO H6 contains a demo that introduces all the best of its tones.

1. Simultaneously press the [🔊] and [SONG] buttons.



Playback starts automatically with the demo song.

2. Press the [MENU/EXIT] button to leave the demo function.

NOTE

All rights reserved. Unauthorized use of this material for purposes other than private, personal enjoyment violates applicable laws.

5 Connections Quick Guide

Peripheral Devices

NOTE

Before connecting an external device to the [AUDIO IN] jack, move the [VOLUME] knob counterclockwise to minimize the volume.

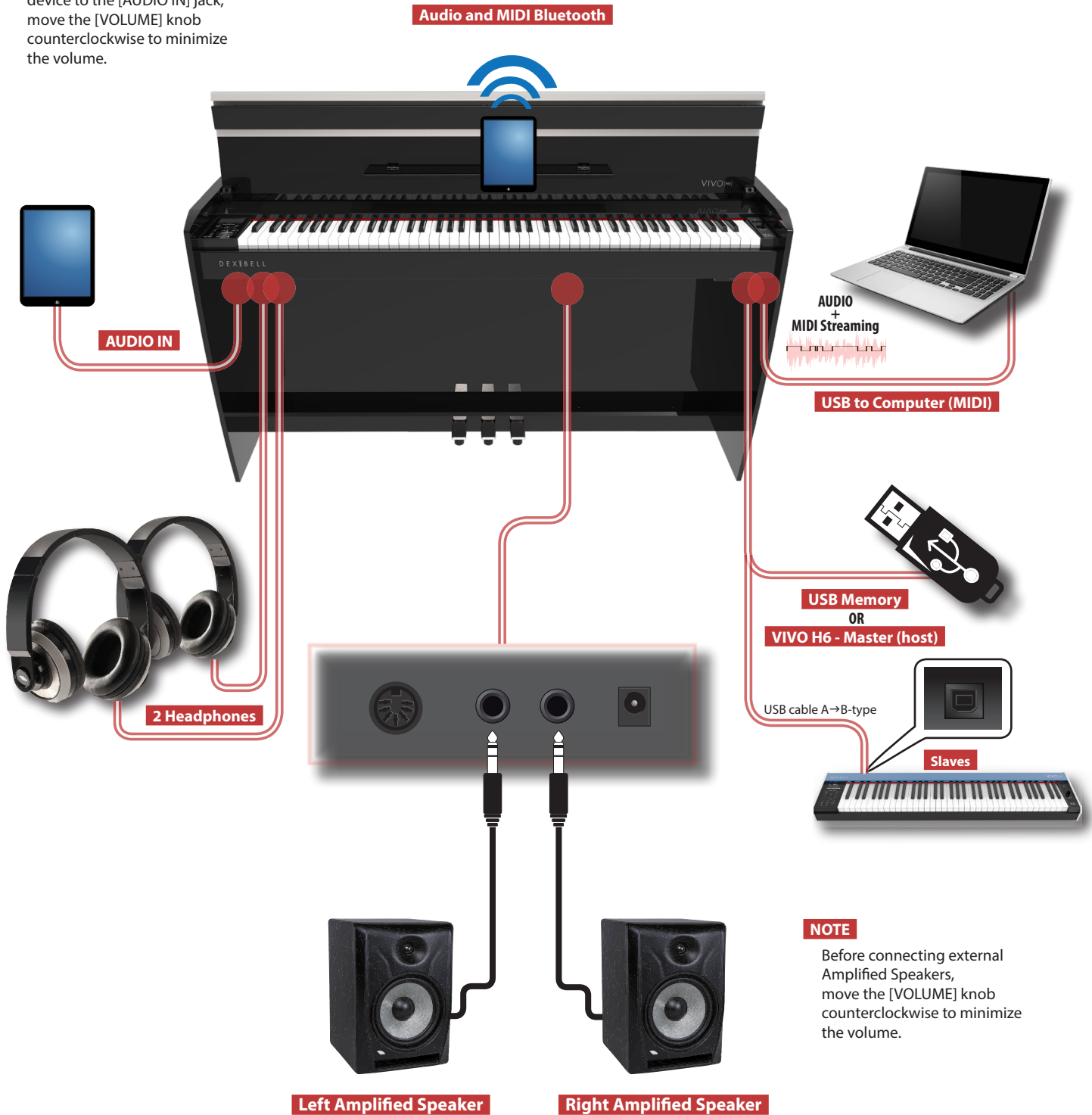

NOTE

Before connecting external Amplified Speakers, move the [VOLUME] knob counterclockwise to minimize the volume.

6 Basic Operation

About the Display and Cursor Operation

This section introduces the information that appears on the main page. Moreover, this section illustrates how to navigate the menu.

Main Page

The VIVO H6 main page contains much useful information.

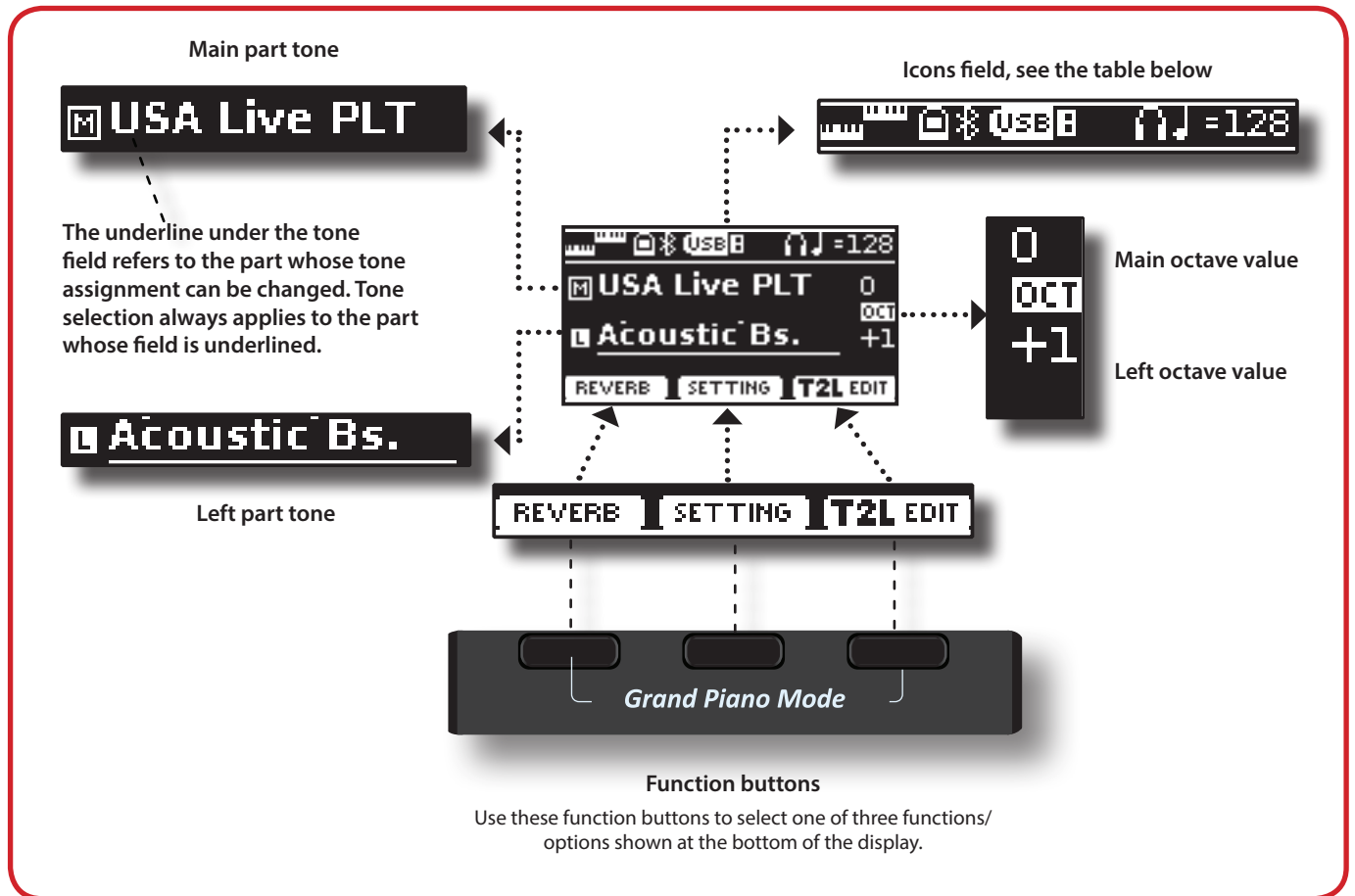

Icons Field	Explanation	Icons Field	Explanation
	Keyboard Mode:		A USB memory is connected to your unit
	• Split		Bluetooth indicator • Steady icon: Connected to a device
	• Layer		The internal speakers are switched off (The "Speaker" parameter is set to "OFF". For complete details on the "Speaker" parameter, check the Global Parameters section in the owner's manual.
	• Split		A headphone is plugged into the [PHONES] output jack
	• Layer		Tempo setting value
	Please consult the complete owner's manual in the Global Parameters section for more information on these settings. 4 Hand is set: "Split+Layer"		
	A computer is connected to the VIVO H6's USB "COMPUTER" port		

Moving the Cursor and Setting Parameter Values

1. Press the [MENU/EXIT] button to access the function groups available.



2. Use the [▲][▼] buttons to select the desired function group.

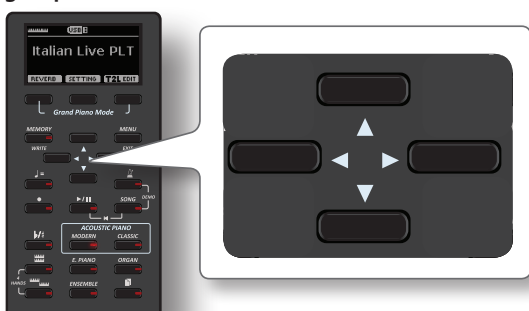

3. Press the [▶] button to enter the selected function group.



4. Use the [▲][▼] buttons to scroll the list of parameters. The selected parameter field is underlined.

5. Use the [◀][▶] buttons to set the desired value.

6. Press the [MENU/EXIT] button to return to the main page.



Assigning the Name You Specify

You'll often have to assign a name to a file. In the following example, we will learn how to give a memory name.

After the selection of saving memory, the display looks:



The VIVO H6 suggests a Memory name.

1. Use the [▲][▼] buttons to select a different character.
2. Use the [◀][▶] buttons to select the next character position you want to change, then use the [▲][▼] buttons again.
3. Press the [A/a/#] Function button to switch between upper- and lower-case characters and numbers.

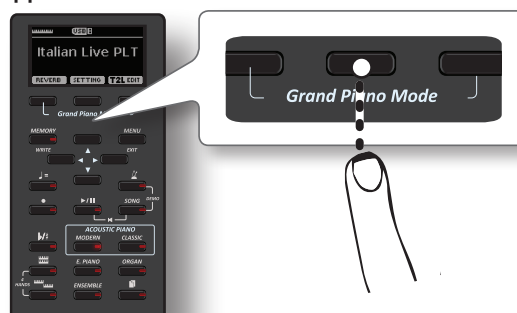

4. To delete the selected character, press the centre and right Function buttons simultaneously.

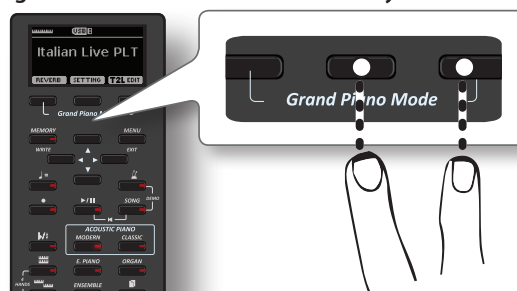

5. To insert a character, simultaneously press the centre and left Function buttons.

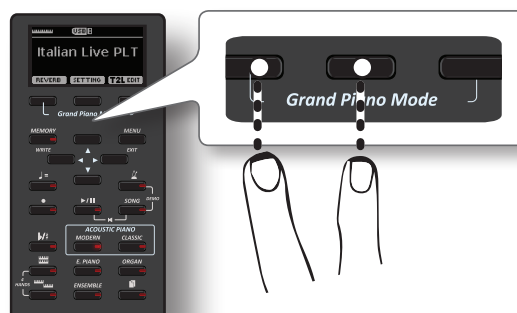

6. Repeat steps (2) and (3) to complete the name.

7 Quick Guide

Reverberation

You can modify the reverberation to the sound to your liking.

Press the Function button that shows "REVERB" at the bottom of the display.

Use the [◀] [▶] buttons to adjust the amount of reverb of the selected part.

Function Buttons

Press these buttons to select functions/options shown at the bottom of the display.

Grand Piano Mode

When you want to reset various settings and play Grand Piano: from the Main page, simultaneously press the first and last Function button.

Menu/Exit Button

Press this button to open and close the menu page where you can view and select all available functions.

Using the metronome

Press the [🔔] button to start the metronome.

To adjust the tempo and time signature use the [♩=] button.

Favorite Settings

HOW TO MEMORIZE YOUR FAVORITE SETTING

The VIVO H6 allows you to memorize your favourite settings for easy recall whenever they're needed. Up to 80 complete setups can be saved.

Press and hold the [MEMORY/WRITE] button to call up the memories page (the indicator of the button flashes).

Use the [▲] [▼] buttons to select one memory location.

Press the function button that shows "SAVE" at the bottom of the display

Use the [▲] [▼] and [◀] [▶] buttons to enter the desired name.

To confirm press the function button that shows "OK" at the bottom of the display

HOW TO RECALL YOUR FAVORITE SETTING

Press the [MEMORY] button to call up the memories page.

Use the [▲] [▼] buttons to select one memory location.

Press the "RECALL" function button located under the display to select the memory.

MEMO

Please note that it is also possible to memorize and recall directly on a USB Memory (commercially available).

Listening the Demo Song

Simultaneously press the [🔔] and [SONG] buttons.

Changing the Tempo/Time Signature

You can adjust the tempo of the metronome.

Press the [♩=] button to display the tempo page.

Use the [▲] [▼] buttons to select the tempo, the time signature field or an available preset tempo

Use the [◀] [▶] buttons to adjust the value.

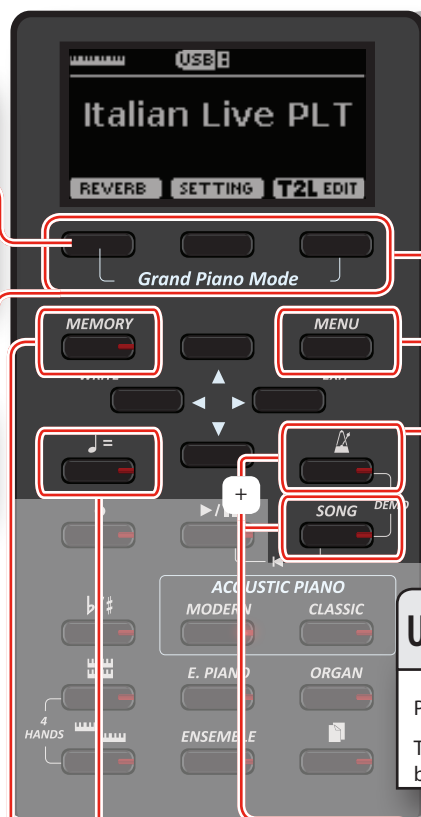

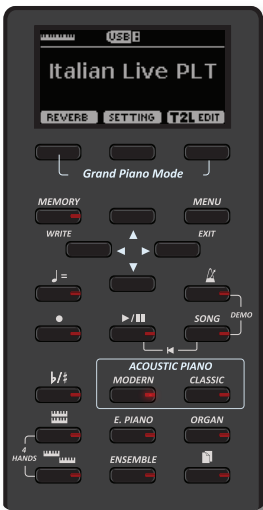

Turning the Power On

Press the VIVO H6's [POWER] switch.

Volume Adjusting

Adjust the volume by rotating the knob

Recording a Song

Press the [RECORD] button to start recording.
 Play your song.
 Press the [RECORD] button again to stop recording.

Selecting and Playing a Song

Press the [SONG] button to display the Song main page.
 Press the "SONG LIST" Function button
 Use the [▲] [▼] buttons to select a song.
 Press the "SELECT" Function button to load the song.
 Press the [▶/||] button to start playing.

Keyboard Mode Selection

At power-on, you play a piano sound over the entire keyboard (The [SPLIT] and [4 HANDS] indicators are off).

Sound A

Press the [SPLIT] button to play two different sounds over the entire keyboard.

Sound A + Sound B

Press the [4 HANDS] button if you want to play different sounds with your left and right hands.

Sound C | Sound A

Split Point

To enter in "4 hands" mode, simultaneously press the [SPLIT] and [4 HANDS] button.

Sound A

Split Point

The keyboard modes listed above are by default. VIVO H6 has two additional modes. One mode plays three different sounds over the keyboard, while split mode allows you to play one sound with your left hand and two with your right hand.

Selecting a Tone

Press one of the family tone buttons
 Press [▲] [▼] to select another desired tone on the list
 Press [◀] [▶] to select another family tone

HOW TO SET A FAVORITE TONE
 Press and hold the family button of the selected tone

Transposing the Keyboard

Press the [b7#] button to call up the page where you can change the transposition value.
 Use the [◀] [▶] buttons to change the value.

VIVO H6 Tone List

Num.	Name	PC	CC00 (MSB)
MODERN			
0001	Italian Live PLT	1	71
0002	Italian PLT	1	70
0003	Italian Classic PLT	1	72
0004	Italian Bright PLT	1	73
0005	Italian Memory PLT	1	74
0006	VIVO Upright	1	2
0007	Elec.Grand	3	2
0008	E.Grand Trem	3	3
0009	Rock Piano	3	1
CLASSIC			
0010	USA Live PLT	1	61
0011	USA PLT	1	60
0012	USA Classic PLT	1	62
0013	USA Bright PLT	1	63
0014	USA Memory PLT	1	64
0015	French Grand	1	80
0016	French Live	1	81
0017	French Classic	1	82
0018	French Bright	1	83
0019	French Memory	1	84
0020	Ragtime	4	0
0021	Harpsi 8'	7	0
0022	Harpsi 4'	7	1
0023	Coupled Hps.	7	2
0024	Harpsi Lute	7	4
0025	Celesta	9	0
E.PIANO			
0026	EPBell Chorus PLT	5	107
0027	EPBell Phaser PLT	5	108
0028	EPBell Tremolo PLT	5	109
0029	EPBell OD PLT	5	110
0030	EPBell Phr+Trm PLT	5	111
0031	EPBell Flanger PLT	5	113
0032	EPBell HardOD PLT	5	114
0033	EPBell Bri+Cho PLT	5	115
0034	EPBell PLT	5	106
0035	70s EP Chorus PLT	5	101
0036	70s EP Phaser PLT	5	102
0037	70s EP Tremolo PLT	5	103
0038	70s EP OD PLT	5	104
0039	70s EP Phr+Trm PLT	5	105
0040	70s EP Bright PLT	5	116
0041	70s EP Bri+Cho PLT	5	117
0042	70s EP Bri+Pha PLT	5	118
0043	70s EP Bri+Tre PLT	5	119
0044	70s EP PLT	5	100
0045	Dirty EPBell PLT	5	112

Num.	Name	PC	CC00 (MSB)
0046	Dyno Stage	5	0
0047	Dyno Trem	5	7
0048	Dyno Bell	5	8
0049	Suitcase	5	1
0050	Phaser EP	5	2
0051	Wurly	5	5
0052	Trem.Wurly	5	6
0053	Soft E.Piano	5	3
0054	Bright E.Piano	5	4
0055	FM Full Tines	6	0
0056	FM E.Piano	6	1
0057	Cool Clav	8	0
0058	Groovy Clav	8	1
0059	Doctor Clav	8	2
0060	Funky Clav	8	3
0061	Wah-Wah Clav	8	4
0062	Drive Clav	8	5
ORGAN			
0063	Jazz Organ	18	0
0064	Pop Organ	17	2
0065	Blues Organ	18	1
0066	Reggae Organ	17	0
0067	R& Organ	17	1
0068	Rock Organ	19	0
0069	Gospel Organ	19	1
0070	888888888	18	2
0071	888233211	18	3
0072	864200357	18	4
0073	686040000	18	5
0074	888604000	18	6
0075	Principal	20	0
0076	Princip&Flute	20	1
0077	Church	20	2
0078	Mixture	20	3
ENSEMBLE			
0079	Large Strings	50	5
0080	Easy Strings	50	10
0081	FastOrchestra	50	4
0082	Attack Strings	49	2
0083	Choir Strings	52	1
0084	MellowStrings	50	6
0085	Soft Strings	50	7
0086	5th Strings	50	8
0087	Slow Analog	50	9
0088	Orchestra	49	1
0089	Classic Choir	53	1
0090	Space Vox	55	1
0091	Mmh Choir	53	0

Num.	Name	PC	CC00 (MSB)
0092	Choir Pad	54	1
0093	Synth Vox	55	0
0094	Warm Pad	90	0
0095	Organ Pad	90	3
0096	Square Pad	90	2
0097	Full Brass	62	3
0098	Trumpet Sect.	57	3
0099	Trumpet	57	2
0100	Tenor Sax	67	0
0101	Soprano Sax	65	0
0102	Alto Sax	66	0
0103	Horns	61	0
0104	Classic Trumpet	57	0
0105	Flugelhorn	57	1
 (MORE)			
0106	Vibraphone	12	0
0107	Marimba	13	0
0108	Clarinet	72	0
0109	Flute	74	0
0110	Harmonica	23	0
0111	Oboe	69	0
0112	Viola	42	0
0113	Violin	41	0
0114	Nylon Guitar	25	0
0115	Steel Guitar	26	0
0116	Elec. Bass	34	2
0117	Soft Slap Bs	37	0
0118	Hard Slap Bs	37	1
0119	5 String Bass	34	1
0120	Picked Bs.	35	0
0121	Fingered Bs.	34	0
0122	Double Bass	33	3
0123	Double Bs&Ride	33	4
0124	Acoustic Bs.	33	0
0125	Ac.Bass&Ride	33	1

8 Specifications

ITEMS	VIVO H6	
KEYBOARD TYPE	TP-400 W (Hybrid, Wood) 88 Keys - Weighted, Hammer action, Triple contact Ivory & Ebony feels Escapement	
TECNOLOGY/CPU	Quad Core Cortex @ 1.8 GHz 4GB memory	
TONE GENERATOR	T2L: Sampling and Modelling Technology	
SAMPLING	XXL wave size, holophonic recording up to 15 seconds on lower piano notes	
SOUND WAVE FORMAT	24 bit linear - 48 KHz (Internal processing and DSP at 32 bit floating)	
DIGITAL ANALOG CONVERSION (DAC)	24 bit linear - 48 KHz, Dynamic Range, S/N:106dB	
MAXIMUM POLYPHONY	Unlimited with 320 Oscillator	
SOUNDS	125 including 3 PLATINUM sounds User downloadable from website (Sound Font Compatible), using "seamless changes" technology at sound recall	
MEMORY	Preset: 80 - User: Unlimited loadable from USB Memory	
WAVE MEMORY	3.2 GB fully changable by the user with DEXIBELL and Sound Font format	
KEYBOARD MODE	Layers, Split, 4 Hands, Layer + Split, 3 parts Layer	
TOUCH SENSITIVITY	7 Types + Fixed	
REVERB	24 Types	
EFFECTS	6 independent DSP Effects x 17 types (2 x Main, 2 x Coupled, 2 x Lower) using "seamless changes" technology at effect recall	
MASTER EQUALIZER	3-band Digital Equalizer	
PLAYER AUDIO	.wav, .aiff, .mp3, in all format, frequency and bit rate	
RECORDER AUDIO	.wav (48 kHz, 32-bit floating) on USB Memory	
MASTER TUNING	YES: 415,4Hz to 466,1 Hz (adjustable increments of 0,1 Hz) + 2 Preset (440 Hz, 442 Hz)	
TEMPERAMENT	9 Types	
USER TEMPERAMENT	3 User	
RHYTHM PATTERNS	X MURE APP for i-Phone and i-Pad (FREE) with multitracks audio patterns	
METRONOME	Yes with Tap Tempo + 13 Standard Tempo Preset	
CONTROLS	VOLUME	
MUSIC REST	Yes, reclinable	
PEDALS	Progressive Damper Action Pedal with sympatetic resonance simulation Progressive Soft Pedal / Function assignable Sostenuto Pedal / Function assignable	
KEYBOARD LID	Folding with soft closing and reclining blind	
WIRELESS CONNECTIONS	Audio and MIDI Bluetooth® (4.2 Low Energy) Wi-Fi™ (ready for future software version)	
DISPLAY	Graphic LCD 128 x 64 dots Organic LED, high contrast type	
CONNECTORS	DC IN socket	for supplied AC adaptor
	AUDIO IN jack	Stereo miniature phone type
	Output (L/Mono, R) jacks	1/4-inch phone type x 2
	Phones jacks	1 x Stereo miniature phone type 1 x Stereo 1/4-inch phone type
	USB COMPUTER port	Type B
	USB MEMORY port	Type A
Pedals Connector	DIN connector: Left Pedal (Assignable), Center Pedal (Assignable), Right Pedal	
SPEAKERS	2 woofer x 8.9 cm (3.5 inches) 2 tweeter x 1,3 cm (0,5 inches)	
RATED POWER OUTPUT	30 W x 2 max	
DSP ON AMPLIFIER	Dynamic EQ - 3 Band Compressor	
AUTO POWER-ON AFTER SHUT-DOWN	Yes, selectable	
VOLUME LEVEL SPL	108.1 dB max	
POWER SUPPLY	24V DC 2.5 A , supplied AC/DC adaptor	
POWER CONSUMPTION	Stand By: < 0,2 W Maximum: 32 W "ErP" LEVEL VI for Echo efficiency on stand-by consumption	
DIMENSIONS	1420 (W) x 385 (D) x 787 mm (H) 55-15/16 (W) x 15-3/16 (D) x 31(H) inches	
WEIGHT	55 kg (excluding AC adaptor) 121 lbs 5 oz (excluding AC adaptor)	
PACKAGE	1 box	
SUPLIED ACCESSORIES	Quick Guide, AC adaptor (DEXIBELL DYS865-240250W)	
OPTIONS (sold separately)	Headphone: DEXIBEL DX HF7, Bench: DEXIBELL DX BENCH	

- Bluetooth® is registered trademarks of Bluetooth SIG, Inc.
- Wi-Fi™ is registered trademarks of Wi-Fi Alliance.

NOTE

In the interest of product, the specification and description are subject to change without notice.



This product complies with the requirements of EMC Directive 2014/30/EU.

For European Countries

For Canada

NOTICE

This Class B digital apparatus meets all requirements of the Canadian Interference-Causing Equipment Regulations. The AC adapter of this unit complies with the "CAN ICES-003 (B) / NMB-003 (B)" specifications.

AVIS

Cet appareil numérique de la classe B respecte toutes les exigences du Règlement sur le matériel brouilleur du Canada. L'adaptateur secteur de cet appareil numérique est conforme aux spécifications «CAN ICES-003 (B) / NMB-003 (B)».

IMPORTANT NOTICE FOR THE UNITED KINGDOM

IMPORTANT: THE WIRES IN THIS MAINS LEAD ARE COLOURED IN ACCORDANCE WITH THE FOLLOWING CODE.

BLUE: NEUTRAL
BROWN: LIVE

As the colours of the wires in the mains lead of this apparatus may not correspond with the coloured markings identifying the terminals in your plug, proceed as follows:

The wire which is coloured BLUE must be connected to the terminal which is marked with the letter N or coloured BLACK.
The wire which is coloured BROWN must be connected to the terminal which is marked with the letter L or coloured RED.
Under no circumstances must either of the above wires be connected to the earth terminal of a three pin plug.

European Community Declaration of Conformity

English	Hereby, DEXIBELL, declares that this VIVO H6 is in compliance with the essential requirements and other relevant provisions of Directive 2014/53/EU.
Italiano [Italian]	Con la presente DEXIBELL dichiara che questo VIVO H6 è conforme ai requisiti essenziali ed alle altre disposizioni pertinenti stabilite dalla direttiva 2014/53/UE.
Français [French]	Par la présente DEXIBELL déclare que l'appareil VIVO H6 est conforme aux exigences essentielles et aux autres dispositions pertinentes de la directive 2014/53/UE.
Deutsch [German]	Hiermit erklärt DEXIBELL, dass sich das Gerät VIVO H6 in Übereinstimmung mit den grundlegenden Anforderungen und den übrigen einschlägigen Bestimmungen der Richtlinie 2014/53/EU befindet.
Nederlands [Dutch]	Hierbij verklaart DEXIBELL dat het toestel VIVO H6 in overeenstemming is met de essentiële eisen en de andere relevante bepalingen van richtlijn 2014/53/EU.
Español [Spanish]	Por medio de la presente DEXIBELL declara que el VIVO H6 cumple con los requisitos esenciales y cualesquiera otras disposiciones aplicables o exigibles de la Directiva 2014/53/UE.
Português [Portuguese]	DEXIBELL declara que este VIVO H6 está conforme com os requisitos essenciais e outras disposições da Directiva 2014/53/UE.
български [Bulgarian]	С настоящото DEXIBELL декларира, че това устройство VIVO H6 е в съответствие със съществените изисквания и други приложими разпоредби на Директиви 2014/53/ЕС.
Hrvatski [Croatian]	DEXIBELL ovim putem izjavljuje da je ovaj uređaj VIVO H6 sukladan osnovnim zahtjevima i ostalim bitnim odredbama Direktiva 2014/53/EU.
Česky [Czech]	DEXIBELL tímto prohlašuje, že tento VIVO H6 je ve shodě se základními požadavky a dalšími příslušnými ustanoveními směrnice 2014/53/EU.
Dansk [Danish]	Undertegnede DEXIBELL erklærer herved, at følgende udstyr VIVO H6 overholder de væsentlige krav og øvrige relevante krav i direktiv 2014/53/EU.
Eesti [Estonian]	Käesolevaga kinnitab DEXIBELL seadme VIVO H6 vastavust direktiivi 2014/53/EL põhinõuetele ja nimetatud direktiivist tulenevatele teistele asjakohastele sätetele.
Ελληνική [Greek]	ΜΕ ΤΗΝ ΠΑΡΟΥΣΑ DEXIBELL ΔΗΛΩΝΕΙ ΟΤΙ VIVO H6 ΣΥΜΜΟΡΦΩΝΕΤΑΙ ΠΡΟΣ ΤΙΣ ΟΥΣΙΩΔΕΙΣ ΑΠΑΙΤΗΣΕΙΣ ΚΑΙ ΤΙΣ ΛΟΙΠΕΣ ΣΧΕΤΙΚΕΣ ΔΙΑΤΑΞΕΙΣ ΤΗΣ ΟΔΗΓΙΑΣ 2014/53/ΕΕ.
Íslenska [Icelandic]	Hér, DEXIBELL, því yfir að þetta VIVO H6 tæki er í samræmi við grunnkröfur og önnur viðeigandi ákvæði tilskipana 2014/53/ ESB
Latviešu valoda [Latvian]	Ar šo DEXIBELL deklarē, ka VIVO H6 atbilst Direktīvas 2014/53/ES būtiskajām prasībām un citiem ar to saistītajiem noteikumiem.
Lietuvių kalba [Lithuanian]	Šiuo DEXIBELL deklaruoją, kad šis VIVO H6 atitinka esminius reikalavimus ir kitas 2014/53/ES Direktyvos nuostatas.
Malti [Maltese]	Hawnhekk, DEXIBELL, jiddikjara li dan VIVO H6 jikkonforma mal-htigijiet essenzjali u ma provvedimenti oħrajn rilevanti li hemm fid-Direttiva 2014/53/UE.
Magyar [Hungarian]	Alulírott, DEXIBELL nyilatkozom, hogy a VIVO H6 megfelel a vonatkozó alapvető követelményeknek és az 2014/53/EU irányelv egyéb előírásainak.
Norsk [Norwegian]	Herved DEXIBELL, erklærer at denne VIVO H6 enheten, er i samsvar med de grunnleggende kravene og andre relevante bestemmelser i direktivene 2014/53/EU.
Polski [Polish]	Niniejszym DEXIBELL oświadczam, że VIVO H6 jest zgodny z zasadniczymi wymogami oraz pozostałymi stosownymi postanowieniami Dyrektywy 2014/53/UE.
Română [Romanian]	Prin prezenta, DEXIBELL declară că acest dispozitiv VIVO H6 este în conformitate cu cerințele esențiale și alte prevederi relevante ale Directivei 2014/53/UE.
Slovenščina [Slovenian]	DEXIBELL izjavlja, da je ta VIVO H6 v skladu z bistvenimi zahtevami in ostalimi relevantnimi določili direktive 2014/53/EU.
Slovenčina [Slovak]	DEXIBELL týmtovyhlasuje, že VIVO H6 spĺňa základné požiadavky a všetky príslušné ustanovenia Smernice 2014/53/EU.
Suomi [Finnish]	DEXIBELL vakuuttaa täten että VIVO H6 tyyppinen laite on direktiivin 2014/53/EU oleellisten vaatimusten ja sitä koskevien direktiivin muiden ehtojen mukainen.
Svenska [Swedish]	Härmed intygar DEXIBELL att denna VIVO H6 står i överensstämmelse med de väsentliga egenskapskrav och övriga relevanta bestämmelser som framgår av direktiv 2014/53/EU.

DEXIBELL

DEXIBELL
is a brand of

PROEL SPA
(Worldwide Headquarters)
Via alla Ruenia, 37/43
64027 Sant'Omero (TE) - ITALY
Tel. +39 0861 81241
Fax +39 0861 887865
P.I. 00778590679
N.Reg.AEE IT 0802000002762

info@dexibell.com
www.dexibell.com

